

UTS: Engineering Course Template

Course: C10073v7 BE BSci
Major: General Engineering

C10074v5 BE BSci Dip Eng Prac
C10075v6 BE BMedSci
C10076v6 BE BMedSci Dip Eng Prac
C10078v6 BE BBio
C10079v5 BE BBio Dip Eng Prac

Stage 1	Stage 2	Stage 3	Stage 4	Stage 5	Stage 6	Stage 7	Stage 8	Stage 9	Stage 10	Stage 11	Stage 12		
33130 Maths Mod 1 6 <i>Core</i>	33230 Maths Mod 2 6 33130 Maths Mod 1 <i>Core</i>	Option 6 <i>MAJ</i>	48110 Engineering Experience 1 0	48240 Design & Inno Fundamentals 6 33130 Maths Mod 1 48230 Eng Comm <i>Core</i>	48260 Eng Pro Man 6 48240 Design&Inno Fund 48122 EPR1 OR 96 CP <i>Core</i>	48250 Eng Eco & Fin 6 48230 Eng Comm 48240 Design&Inno Fund & 87CP <i>Core</i>	48130 Engineering Experience 2 0	48210 Interrogating Technology 6 48250 Eng Eco & Fin <i>MAJ</i>	48270 Entrepreneur & Commercialisation 6 120cp <i>Core</i>	48016 Capstone A 6 48260 Eng Pro M/Ment 48142 EPR2 [C] OR 144 CP <i>MAJ</i>	48026 Capstone B 6 48016 Capstone A <i>MAJ</i>		
48230 Eng Comm 6 <i>Core</i>	Option 6 <i>MAJ</i>	Option 6 <i>MAJ</i>		Option 6 <i>MAJ</i>	Option 6 <i>MAJ</i>	Option 6 <i>MAJ</i>		Option 6 <i>MAJ</i>	Option 6 <i>MAJ</i>	Option 6 <i>MAJ</i>	Option 6 <i>MAJ</i>	Option 6 <i>MAJ</i>	
58037 Phys Mod 6 <i>Core</i>	48023 Programming Fundamentals OR 48221 Engineering Computations 6 33130 Maths Mod 1 <i>MAJ</i>	Option 6 <i>MAJ</i>		Option 6 <i>MAJ</i>	Science Subject 6 <i>MAJ</i>	Science Subject 6 <i>MAJ</i>		Option 6 <i>MAJ</i>	Option 6 <i>MAJ</i>	Option 6 <i>MAJ</i>	Option 6 <i>MAJ</i>	Science Subject 6 <i>MAJ</i>	Science Subject 6 <i>MAJ</i>
Science Subject 6	Science Subject 6	Science Subject 6		Science Subject 6	Science Subject 6	Science Subject 6		Science Subject 6	Science Subject 6	Science Subject 6	Science Subject 6	Science Subject 6	Science Subject 6
	48121 EPP1 3 48230 Eng Comm [C] & 1 CP <i>EPP</i>	48122 EPR1 3 48110 EE1 <i>EPP</i>		48141 EPP2 3 48122 EPR1 OR 48120 REP1 <i>EPP</i>	48142 EPR2 3 48130 EE2 48141 EPP2 & 129 CP <i>EPP</i>	48100 Professional Practice 0 126 CP							

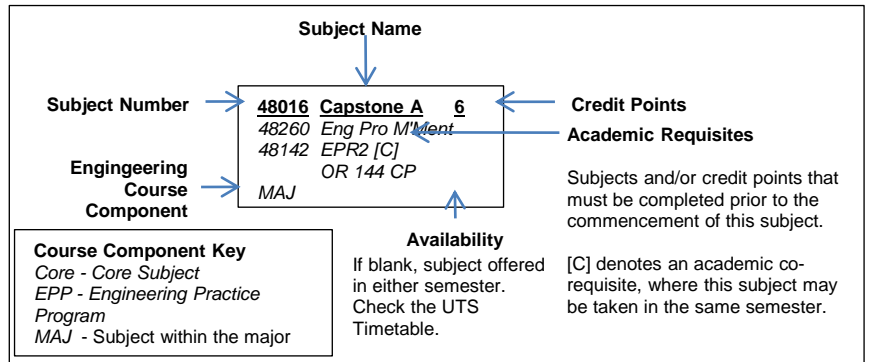

UTS Timetable remains the definitive source on subject availability
Your study plan defines course requirements
For further assistance, contact Student Centre at 1300 275 887

UTS: Engineering Course Template

Course: C10073v7 BE BSci
Major: General Engineering

C10074v5 BE BSci Dip Eng Prac
C10075v6 BE BMedSci
C10076v6 BE BMedSci Dip Eng Prac
C10078v6 BE BBio
C10079v5 BE BBio Dip Eng Prac

Select 90 CP from the following options (with the approval of DUP)

48023 Programming Fundamentals MAJ	48331 Mech of Solids 48321 Eng Mechanics OR 48620 Fund Mech Eng MAJ	48362 Hydraulics & Hydro 48641 Fluid Mechanics MAJ	48410 Intro to ICT Eng MAJ	48471 ICT Analysis 48240 Design&Inno Fund 48260 Eng Pro M'tment [C] & 120 CP MAJ	48541 Signal Theory 33230 Maths Mod 2 MAJ	48580 Advanced Control 48560 Intro Control MAJ	48621 Manufacturing Eng 48610 Intro to M&M Eng MAJ	48660 Dynamics & Control 48640 Machine Dynamics MAJ	48750 Network Plan & Management 48740 Comm Networks 33230 Maths Mod 2 MAJ	48881 48840 MAJ
48024 Applications Programming 48023 Programming Fundamentals MAJ	48340 Construction 48310 Intro to Civil & Enviro Eng MAJ	48364 Mat Testing 48331 Mech of Solids MAJ	48430 Embedded C 48441 Intro Digital Sys [C] MAJ	48481 ICT Design 48471 ICT Analysis MAJ	48550 Renewable Energy Sys 48531 Electromechanical AU MAJ	48581 Digital Electronics 48530 Circuit Analysis 48570 Data Acq & Dist MAJ	48622 Mechatronics 1 48510 Intro to Electrical Engineering MAJ	48661 Heat Transfer 48641 Fluid Mechanics MAJ	48770 Continuous Communications 48541 Signal Theory OR 48540 Signals and Sys MAJ	60101 MAJ
48080 Intro to Innov MAJ	48342 Structural Behav'r & Design 48331 Mech of Solids 48352 Constr Mat [C] MAJ	48365 Mat Perform 48366 Steel & Timber Des 48364 Materials Testing 48353 Concrete Design [C] MAJ	48433 Software Archi 48440 Software Eng Prac OR 48024 Applications Program MAJ	48510 Intro to Elec Eng MAJ	48551 Analog Electronics 48530 Circuit Analysis 48570 Data Acq & Dist MAJ	48582 Power Sys Analysis & Des 48572 Power Circ't Theory MAJ	48623 Mechatronics 2 48622 Mechatronics 1 OR 48441 Intro Digital Sys MAJ	48662 Mechanical Applications 48640 Machine Dynamics 48642 Str of Eng Mat MAJ	48771 Discrete Comm 48541 Signal Theory MAJ	68038 33230 68037 48520 MAJ
48221 Engineering Computations 33130 Maths Mod 1 MAJ	48349 Structural Analysis 48331 Mech of Solids 33230 Maths Mod 2 MAJ	48366 Steel & Timber Design 48349 Structural Analysis 48352 Constr Mat [C] MAJ	48434 Embedded Software 48430 Embedded C MAJ	48520 Elec & Circuits 48510 Intro to Elec Eng 33130 Maths Mod 1 MAJ	48560 Intro Control 48540 Signals & Sys MAJ	48583 Power Sys Oper'n & Prot'n 48572 Power Circ't Theory MAJ	48640 Machine Dynamics 48620 Fund of Mech Eng MAJ	48663 Adv Manufacturing 48650 Mech Design 2 48621 Manufacturing Eng MAJ	48780 Mobile Comm 48770 Continuous Comm MAJ	61275 48720 MAJ
48310 Intro to Civil & Enviro Eng MAJ	48350 Enviro & San'n Eng 60101 Chem & Mat Sci OR 65111 Chemistry 1 MAJ	48370 Road & Transport Eng 48330 Soil Behaviour MAJ	48440 Software Eng P 48024 Applications Programming MAJ	48521 Fund Elec Eng 48510 Intro to Elec Eng 68037 Phys Mod 33230 Maths Mod 2 [C] MAJ	48561 Power Elec & Drives 48531 Electro Autom MAJ	48600 Mech Design 1 48331 Mech of Solids 48621 Manufacturing Eng 48240 Design&Inno Fund MAJ	48641 Fluid Mech 33230 Maths Mod 2 MAJ	48670 M&M Design 48650 Mech Design 2 MAJ	48821 Principles of Environmental Eng 65111 Chemistry 1 MAJ	48436 48730 MAJ
48320 Surveying MAJ	48352 Constr Mat 33230 Maths Mod 2 65111 Chemistry 1 OR 60101 Chem & Mat Sci MAJ	48371 Adv Eng Comp 48221 Eng Computations 48349 Structural Analysis & 120 CP MAJ	48441 Intro Digital Sys 48510 Intro Elec Eng MAJ	48530 Circuit Analysis 48520 Elec & Circuits 48521 Fund of Elec Eng MAJ	48570 Data Acq Dist 48441 Intro Digital Sys 48540 Signals and Sys OR 48520 Elec & Circuits AND 48541 Sig Theory MAJ	48601 Mech Vib & Measurement 48640 Machine Dynamics 48660 Dynam & Control MAJ	48642 Strength of Eng Materials 48331 Mech of Solids MAJ	48720 Network Fundamentals MAJ	48840 Water Supply & Wastew'r M'tment 65111 Chemistry 1 OR 60101 Chem & Mat Sci MAJ	61900 48410 48720 MAJ
48321 Eng Mechanics 33130 Maths Mod 1 [C] 68037 Physical Mod [C] MAJ	48353 Concrete Design 48349 Structural Analysis 48352 Construct'n Mat [C] MAJ	48372 Water Quantity & Quality Process 48362 Hydraulics & Hydro MAJ	48450 Real-Time Oper'n Sys 48434 Embedded S'ware MAJ	48531 Electro Autom 33230 Maths Mod 2 48520 Elec and Circ's OR 48660 Dynam & Control MAJ	48571 Elec Machines 48531 Electromech Auto 48530 Circuit Analysis 68038 Adv Maths & Phys MAJ	48610 Intro to M&M Eng MAJ	48650 Mech Design 2 48600 Mech Design 1 48642 Str of Eng Mat MAJ	48730 Network Securit 48740 Comm Networks OR 31277 Routing & Internet OR 31471 Networking 2 MAJ	48850 Enviro Planning & Law 87 CP MAJ	61101 48541 48520 91400 MAJ
48330 Soil Behaviour 48331 Mech of Solids [C] MAJ	48360 Geotechnical Eng 48330 Soil Behaviour MAJ	48389 Comp M&D 48366 S&T Des [C] 48353 Concrete Design & 144 CP MAJ	48451 Adv Digital Systems 48441 Intro Digital Sys MAJ	48540 Signals & Sys 48530 Circuit Analysis MAJ	48572 Power Circuit Theory 48530 Circuit Analysis MAJ	48620 Fund Mech Eng 48610 Intro to M&M Eng 68037 Phys Mod 33130 Maths Mod 1 MAJ	48651 Thermo-dynamics 33230 Maths Mod 2 68037 Phys Mod MAJ	48740 Comm Networks 48720 Network Fund MAJ	48860 Poll'n Control & Waste M'tment 48840 Water Supply OR 48350 Enviro & S'tion Eng MAJ	61401 MAJ

UTS Timetable remains the definitive source on subject availability

Your study plan defines course requirements

For further assistance, contact Student Centre at 1300 275 887

UTS: Engineering Course Template

Course: C10073v7 BE BSci
Major: General Engineering

C10074v5 BE BSci Dip Eng Prac
C10075v6 BE BMedSci
C10076v6 BE BMedSci Dip Eng Prac
C10078v6 BE BBio
C10079v5 BE BBio Dip Eng Prac

Water & Enviro	6
Design	
<i>Hydraulics & Hydro</i>	
<i>Water Supply</i>	
<i>& 144 CP</i>	
<i>SPR</i>	
Chem &	6
Materials Sci	
Adv Math Phys	6
<i>Maths Modelling 2</i>	
<i>Phys Mod</i>	
<i>Elec & Circuits</i>	
<i>SPR</i>	
Mobile	6
Networking	
<i>Network Fundamenta</i>	
<i>SPR</i>	
Digital Forensic	6
<i>Network Security</i>	
<i>SPR</i>	
Fundamentals	6
of Security	
<i>Intro ICT Eng</i>	OR
<i>Network Fund</i>	
Fund of Biomed	6
<i>Signal Theory</i>	
<i>Electronics & Circuits</i>	
<i>Human Anatomy & Ph</i>	
<i>SPR</i>	

UTS Timetable remains the definitive source on subject availability
Your study plan defines course requirements
For further assistance, contact Student Centre at 1300 275 887